



# Fluidix® Series Steam-Powered Ultra-Pure Water Heating System



**HEATEFLEX**

## When High Flows of Hot DI Water Are Required, Heateflex Offers a Solution – Fluidix Series DI Water Heaters

### Benefits:

- Low Cost of Operation
- Consistent Process Temperature with PLC Controls
- High Purity PFA/PVDF Wetted Surfaces
- Field Proven Technology for Reliable Operation

### Experience in Industry

Fluidix Steam-Powered Heating Equipment entered the market place in 1982. From that point in time, the method for heating mass amounts of deionized water changed forever. Currently, Fluidix equipment heats over 400 million gallons of DI water each year throughout the semiconductor industry, with many of the original units still in production.

The industry experience of Heateflex Corporation and Fluidix helps build reliable machines that reduce the cost of heating high flows of DI water. In addition, customers using Fluidix equipment achieve ZERO-defect yields in sub-micron geometries on 200mm wafers.

In high flow demands, no other model comes close!

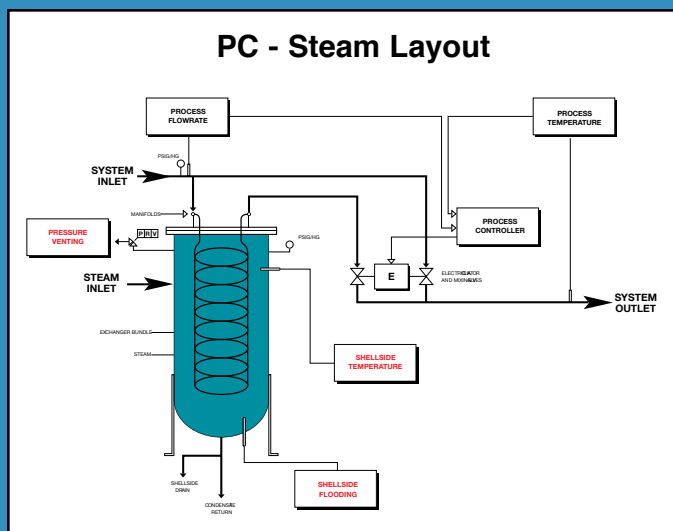

### Why Steam?

When selecting an ultra-pure heater, the question to use steam or electric usually comes up. In general, for higher DI water flows, a unit that utilizes steam costs less than a comparable electric unit. In addition, the operational cost savings typically pay for the equipment within a year and a half of service.



### Operation Savings that Really Add Up

Basis: 30 gpm heated from 20°C to 80°C

	Steam	Electric
Yearly Energy Cost*	\$62,406	\$145,615
First Year Savings:	\$83,209	
Five-Year Savings:	\$416,045	
Ten-Year Savings:	\$832,090	

\* Based on average U.S. energy costs, corrected for 82% boiler efficiency and 50% usage factor.

The Fluidix Series DI Water Heater offers several other reasons to consider steam. In this design there are no heater elements to burn out and the system can be run dry or at zero flow without causing any damage to the unit. The intrinsically safe design has an automatic shutdown and isolation/contamination prevention system built into each unit. A purge system is not required because the water can be heated to >100°C during standby. The heater medium used in the Fluidix is a low-pressure steam operating on 15 psig, and steam throttling is not required.



## Features:

- Uses Low Pressure Steam for Low Cost of Ownership
- Easy to Use PLC/Touchscreen Control
- Reduce Your Fab Equipment with Single Exchanger System that Provides Up to 100 GPM
- Mixing Valve Temperature Control for +/- 0.5°C Accuracy (See Temperature Graph)

### Temperature Performance

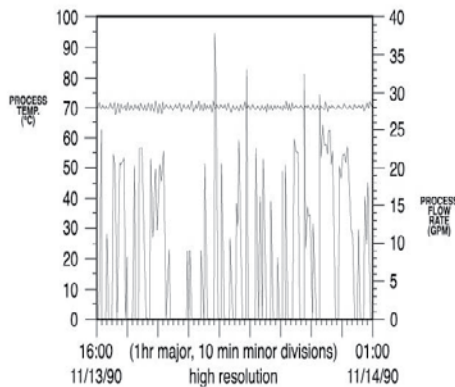

This chart was obtained by means of a DataTrax® system monitoring a customer's actual process.

## Safety Systems

As with all Heateflex heating products, the Fluidix steam-powered heating equipment and water-powered heating equipment is designed with safety in mind. The unit can be divided into two sides, the Shellside (steam/water side) and the Tubeside (process side). Each side has different safeties incorporated into the design.

## Shellside (Steam) Safeties

The main safeties on the Shellside are the over-temperature RTD and the pressure relief valve. The RTD monitors the incoming steam to assure proper temperature regulation, and the safety pressure relief valve keeps the unit operating in low pressure conditions.

## Tubeside (Process) Safeties

The Tubeside is more critical to yields and has several safeties incorporated to protect it.

- Over-Temperature Protection. The process temperature is monitored to assure proper regulation.
- PTFE pressure-relief valve (set to approximately 68 psig) keeps the unit operating at safe pressures

In addition, the Tubeside has three safeties to ensure the integrity and purity of the process.

- Low-Pressure Monitoring
- Leak Detection
- Auto-Isolation with Cold Bypass

The low-pressure monitoring and leak detection check the integrity of the PFA process feed line. The auto-isolation with cold bypass will self contain the unit while allowing the DI water to bypass and complete the cycle.

## Purity

- System Designed to Maintain Process Purity For Years with All PFA & PVDF Wetted Surfaces
- No Measurable Changes in TOC Bacteria, Silica and Particles >0.06m
- Ionic Contamination Ranges from Non-Detectable to 0.04 ppb



### Water Purity after 5 years of service

Mach #	CATIONS					ANIONS					
	Na+ (ppb)	NH <sub>4</sub> + (ppb)	K+ (ppb)	Mg++ (ppb)	Ca++ (ppb)	F- (ppb)	Cl- (ppb)	NO <sub>2</sub> - (ppb)	NO <sub>3</sub> - (ppb)	PO <sub>4</sub> = (ppb)	SO <sub>4</sub> = (ppb)
1	0.006	0.235	ND	ND	0.004	0.016	0.009	0.005	ND	ND	ND
2	0.003	0.121	ND	ND	0.005	0.006	0.005	0.007	ND	ND	ND
3	ND	0.139	ND	ND	ND	0.002	ND	ND	ND	ND	ND
4	0.005	0.122	ND	ND	ND	0.002	0.005	ND	ND	ND	ND
5	ND	0.185	ND	ND	ND	0.013	0.003	0.004	ND	ND	ND
6	0.003	0.142	ND	ND	ND	0.004	0.005	0.004	ND	ND	ND
7	0.004	0.229	ND	ND	ND	0.011	0.004	0.004	ND	ND	ND
8	0.003	0.263	ND	ND	ND	0.018	0.004	0.006	ND	ND	ND
9	ND	0.167	ND	ND	ND	0.008	0.002	0.003	ND	ND	ND
10	0.008	0.170	ND	ND	0.007	0.010	0.002	0.005	ND	ND	ND
11	0.004	0.181	0.026	ND	0.0005	0.012	0.009	0.007	ND	ND	ND
12	0.002	0.147	ND	ND	ND	0.007	0.007	ND	ND	ND	ND
13	ND	0.167	ND	ND	ND	0.005	0.004	ND	ND	ND	ND
14	0.002	0.199	0.033	0.004	0.003	0.007	0.025	0.007	0.015	ND	ND
15	ND	0.181	ND	ND	ND	0.003	0.004	0.012	ND	ND	ND
UPW Loop	ND	0.085	ND	ND	ND	0.004	ND	ND	ND	ND	ND

# Fluidix® Series Steam-Powered Ultra-Pure Water Heating Systems Specifications

Model	Length	Width	Height
PC3273	38"	38"	78"
PC-5760	57"	57"	78"
PC-6810	57"	57"	78"
PC-11217	68"	68"	78"
PC-11350	68"	68"	78"

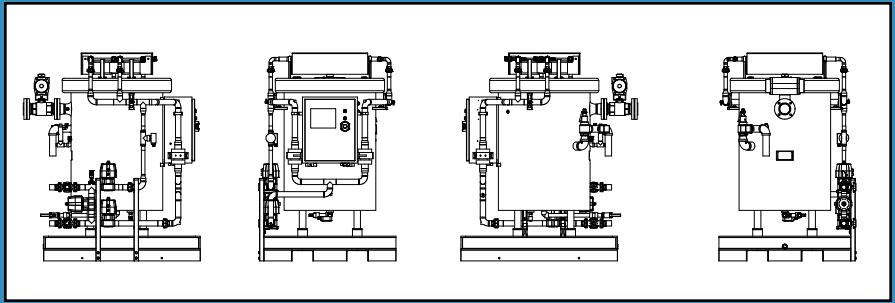

Model	GPM	Temp. Capability	Process In/Out	Steam In/Out ANSI Flange
PC3273	15	20 - 88° C	32mm	2"
PC-5760	25	20 - 88° C	50mm	3"
PC-6810	30	20 - 91° C	50mm	3"
PC-11217	40	20 - 93° C	63mm	4"
PC-11350	50	20 - 91° C	63mm	4"

Wetted Surface Material	PVDF & PFA
Temperature Range	Ambient to 95° C, accurate to ± 0.5° C
Safety Interlocks	Steam Side: Over-Temp RTD & Pressure Relief Valve Process Side: Over-Temp Protection, Pressure Relief Valve, Process Low-Pressure Monitor, Leaks Detection, & Auto-Isolation with Cold Bypass
Minimum Velocity	0.5 GPM (to prevent bacteria growth in DI water)
Maximum Flow	100 GPM
Minimum Pressure	Process Side: 22 PSIG
Maximum Pressure	Steam Side: 15 PSI Process Side: 68 PSI
Boiler Requirements	From 500,000 – 3,000,000 Btu/hr or Approximately 200 kW – 800 kW

**Call today for prices and lead times, or visit us online at [www.heateflex.com](http://www.heateflex.com)**

Heateflex is a Registered Trademark of Heateflex Corporation.

All data is subject to change without notice.  
Copyright ©2011 Heateflex Corporation



405 E. Santa Clara St., Arcadia, CA 91006  
Tel: (626) 599-8566 Fax: (626) 599-9567  
info@heateflex.com www.heateflex.com